



# Owner's Manual

## EchoBed® X

### VasScan Table™ X



Owner \_\_\_\_\_

Model \_\_\_\_\_

Serial # \_\_\_\_\_









Date \_\_\_\_\_

## Table of Contents

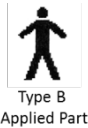
---



Symbols and Definitions .....	3
Safety Warnings & Cautions.....	5
Intended Use.....	7
Safety Features .....	7
Set Up .....	8
Transport Position .....	8
Product Illustration.....	9
Controls and Indicators .....	10
Use Instructions .....	14
Powering the Product.....	14
Locking the Casters.....	15
Hand Control Functions.....	16
Adjusting Surface Height.....	16
Adjusting Fowler.....	16
Adjusting Trendelenburg .....	16
Memory Function .....	17
Hand Control Lock/Unlock.....	17
Under-bed Lights.....	18
Using the VasScan Table™ X Foot Rest.....	19
Using the Carotid Head Rest.....	22
Using the Swing Safety Handrails .....	23
Using the Slide Safety Handrails .....	24
Using the Sonographer Extension.....	25
Foley Bag Clip.....	26
Storing the Hand Control.....	26
Under-bed Lights.....	26
IV Pole and Holder .....	27
Optional Battery .....	27
Positioning Wedge .....	28
Pediatric Adaptor.....	28
Preventative Maintenance .....	29
Expected Life .....	30
Discard the Unit.....	30
Cleaning.....	31
Service Calls .....	33
Troubleshooting Guide .....	34
Specifications .....	35
Warranty .....	46
Return Policy.....	48

## Symbols and Definitions

	<p>Warning, follow instructions for use. Failure to comply may result in injury.</p>
	<p>Warning, sitting is prohibited. Failure to comply may result in injury.</p>
	<p>Warning, standing is prohibited. Failure to comply may result in injury.</p>
	<p>Applied Part complying with specified requirements IEC 60601-1 to provide protection against electric shock, particularly regarding allowable patient leakage current.</p>
	<p>Warning/Caution, consult accompanying documents.</p>
	<p>Any terminal which is intended for connection to an external protective conductor for protection against electric shock in case of a fault.</p>
	<p>In accordance with the European Directive 2002/96/EC on Waste Electrical and Electronic Equipment (WEEE), the product must not be disposed as unsorted municipal waste, but should be collected separately. Consult your instructional policies and local regulations regarding disposal. Contact your Medical Positioning, Inc. Service Representative if additional disposal details are required.</p>
	<p>Manufacturer</p>
	<p>Agency Mark</p>

## Symbols and Definitions

---

	Maximum Patient Weight. Indicates the maximum patient weight that may be placed on the product.
	Safe Working Load. Indicates the sum of the patient weight and accessories that may be placed on the product.

### WARNING / CAUTION / NOTE Definition

The words WARNING, CAUTION, and NOTE carry special meanings and should be carefully reviewed.

---

 WARNING

Identifies a situation that could result in injury to the patient or caregiver.

---

---

 CAUTION

Identifies a situation that could result in equipment damage.

---

### Note

Provides special information to make an important instruction more clear.

### European Union Representative



MDSS GmbH  
Schiffgraben 41  
30175 Hannover, Germany



## Safety Warnings & Cautions

---

### **WARNING:**

Obey these safety instructions to help prevent injury and/or equipment damage:

- Read and understand all warnings in this manual and on the unit itself prior to use with a patient.
- The device should be operated by trained persons only.
- Authorized and qualified persons will be those who are approved by Medical Positioning Inc. to repair or modify the product.
- Do not modify this equipment without authorization of the manufacturer.
- Equipment should only be serviced by authorized personnel.
- The procedures in this manual are only manufacturer's suggestions. The final responsibility for patient care with respect to this device remains with the attending physician.
- Do not use in an oxygen rich environment.
- Do not leave patient unattended while using the product.
- To reduce the risk of electric shock, grounding reliability can only be achieved when the equipment is connected to an equivalent receptacle marked "hospital only" or "hospital grade".
- If damage has occurred to the power cord, immediately remove the cord from service. Failure to do so could result in serious injury or death.
- The battery should be periodically inspected for damage. If damage has occurred to the battery, immediately remove the battery from service. Failure to do so could result in serious injury or death.
- Removal of secured covers may increase the risk of electrical shock. Refer servicing to qualified and approved personnel.
- The potential for electrical shock exists with electrical equipment. Failure to follow facility protocols may cause death or serious injury.
- Ensure the patient is properly secured prior to using the equipment.
- To reduce the risk of a potential injury, lock casters before using equipment.
- Once the product and patient have been properly positioned for the procedure, ensure the casters are locked and the hand controller is placed in a safe position to prevent unwanted contact and unwanted movement of the support surface.
- To reduce the risk of the product becoming unbalanced, always position the product in the lowest reasonable height when moving.

## **Safety Warnings & Cautions**

---

- Verify the area around the product is free of impediments before operating to prevent injury or equipment damage.
- Keep hands and feet clear from beneath the patient surface when lowering surface height or making positioning adjustments in order to avoid possible injury.
- Keep hands and feet clear of the scissor lift mechanism when operating or making positioning adjustments in order to avoid possible injury.
- Keep hands clear of the fowler section hinges during operation to avoid possible injury.
- Sitting at the end of the patient surfaces can result in device instability. Do not allow a patient to sit at the head end of the patient surface.
- The footboard should be used for steep reverse Trendelenburg positions to ensure patient stability.
- Protect vinyl upholstery from sharp objects and abrasion to avoid damage.
- Always read manufacturer's instructions and warnings before using any cleaning product or disinfectant. Refer to instructions located in this manual for vinyl cleaning recommendations.
- Substances such as imaging gels and alcohol will not damage the vinyl surface when immediately removed. Extended exposure for longer than a few minutes can damage the topcoat and will eventually discolor vinyl.
- Do not use abrasives to clean painted surfaces.
- It is recommended that the product be cleaned between patients; please follow your facility's documented policy.
- Keep this manual available for future reference.
- If the product is used adjacent to other electrical equipment, observe the product and the other electrical equipment to ensure they operate as intended.
- Failure to latch Drop Sections may result in patient injury. Verify Drop Sections are locked in position before and after use.
- Verify the head rest is secure prior to using the product.
- Verify the safety handrails are secure prior to using the product and after each handrail adjustment.
- Do not exceed the weight capacity of the product.

## Intended Use

---

This product is intended to be used in an environment where ultrasound and other such diagnostic equipment is present, including hospitals, outpatient facilities, and doctor's offices. The product is intended to be used by trained healthcare professionals who possess the ability to operate the product safely. The product's movements are controlled both manually and electronically via the product's hand control.

The product is not intended for use in oxygen rich environments.

## Safety Features

---

- This product is equipped with multiple automated safety features to prevent danger or damage during use. The entire system is electrically isolated to UL/IEC 60601-1 and CAN/CSA C22.2 No. 601.1 hospital safety standards.
- The actuator assemblies are current overload protected. If overloaded, the actuators will stop and reset automatically.
- The sealed hand control operates the actuators by directing small amounts of low voltage D.C. current to the control box. All of the actuator drives are equipped with internal limit switches which automatically prevent over-extension.

## Set Up

---

The product has been shipped to you in “plug and play” condition. After unpacking the product, we recommend performing an initial test of your product to ensure that each function is in correct working order. After reviewing this manual, you are ready to begin using your product.

STEP	ACTION
1	After removing padding and packaging materials locate primary power supply cord and attach to suitable grounded power outlet.
2	To test actuator function, locate the hand control and depress each button one at a time. (Depressing multiple buttons simultaneously will prevent the motor from operating.)
3	If any function does not operate, perform the test procedures listed in the Troubleshooting Guide.

## Transport Position

---

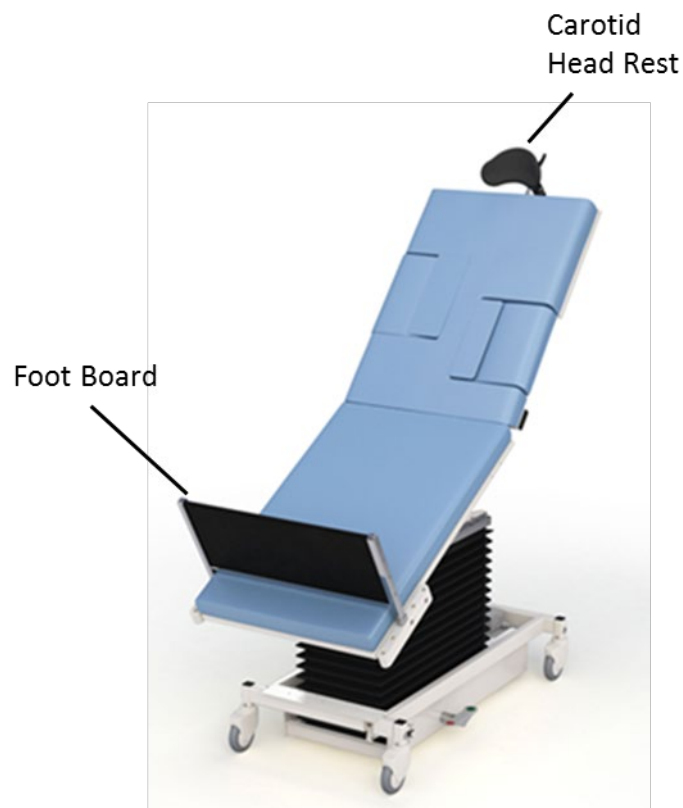
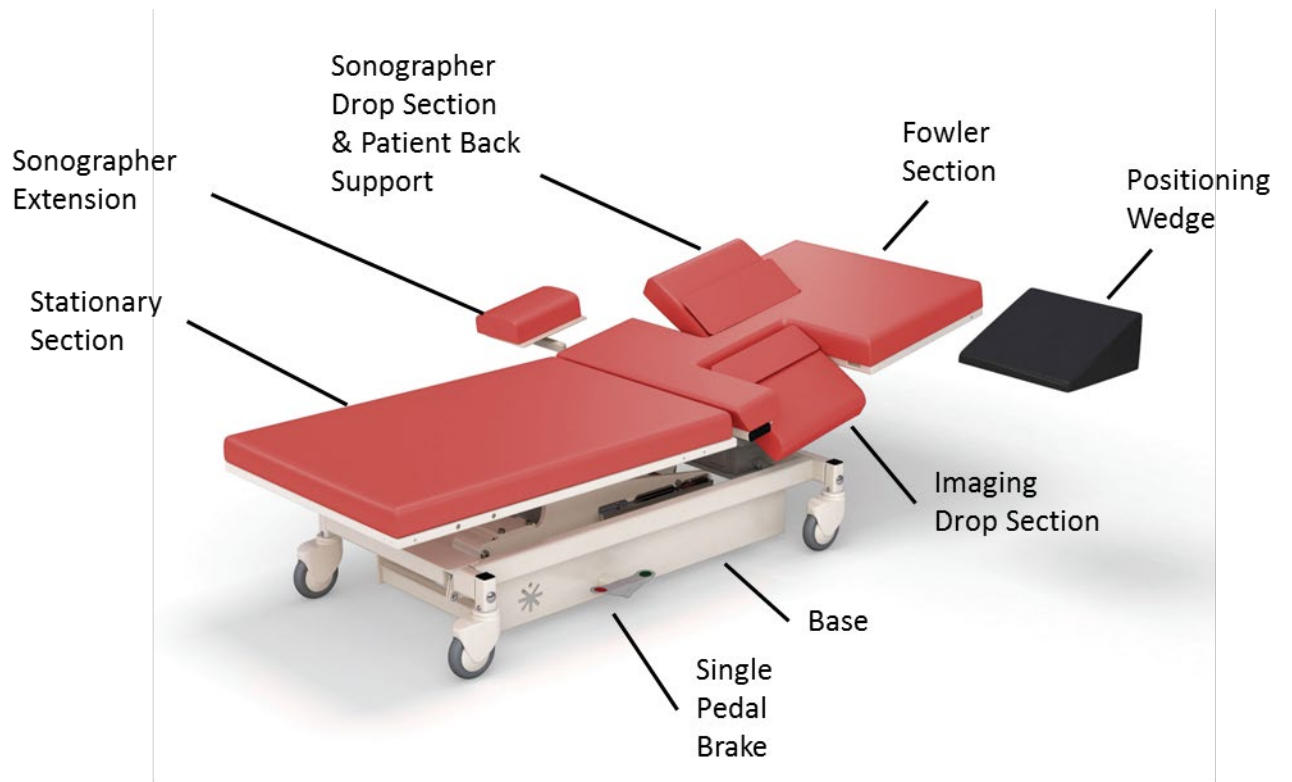

It is recommended that the patient surfaces be in a horizontal position if the product is used to transport patients.

# Product Illustration



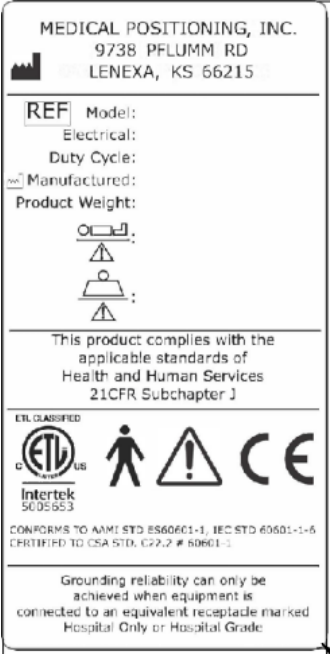

\*Optional features may be shown

# Controls and Indicators



<p>Unique Device Identification Label</p> <ul style="list-style-type: none"> <li>• Serial #</li> <li>• Item #</li> <li>• Item Description</li> <li>• Unique Identifier</li> </ul>	 <p>The MPI label includes the company logo, address (9732 Pflumm RD, Lenexa, KS 66215), website (www.medicalpositioning.com), phone number (800-593-3246), and patent information. It also displays fields for Serial Number (#####), ITEM # (####), Item Description, and GMDN Code, followed by a barcode and the number (01) 0 8488710 00633 8 (21) 0123456.</p>
<p>Certification Label</p>	 <p>The certification label provides detailed technical specifications: REF Model, Electrical, Duty Cycle, Manufactured, and Product Weight. It features safety icons for electrical shock, weight, and a person. The label states compliance with applicable standards of Health and Human Services (21CFR Subchapter J). It is ETL Classified by Intertek (505553) and conforms to ANSI STD 8560601-1, IEC STD 60601-1-6, and CSA STD. C22.2 # 80601-1. A note at the bottom states: 'Grounding reliability can only be achieved when equipment is connected to an equivalent receptacle marked Hospital Only or Hospital Grade.'</p>
<p>Refer to Manual Label</p>	 <p>A blue circular icon depicting a person sitting at a desk and using a laptop, representing the manual label.</p>

## Controls and Indicators

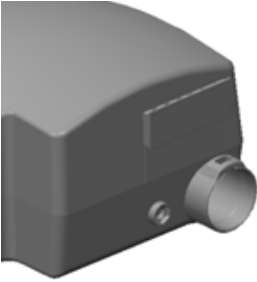
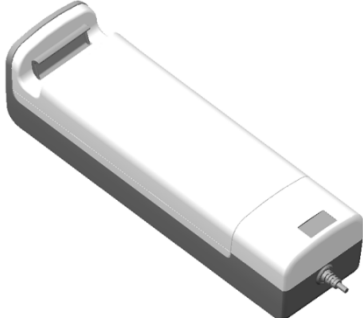

---

<p>No Sitting label</p>	
<p>Hand Control</p> <p><b>Note:</b> Hand control functions will vary depending on the model purchased. Your hand control may differ from the images to the right.</p>	

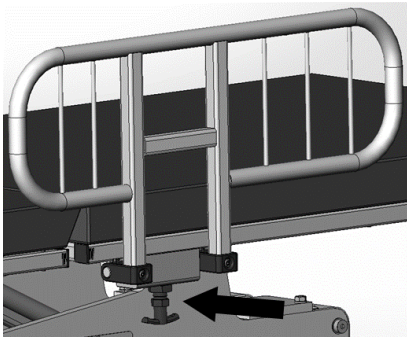
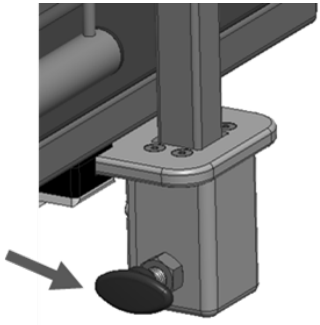
## Controls and Indicators

<p>AC Input</p>	 A black, rectangular control unit with a circular dial on the front and a small indicator light.
<p>Battery</p>	 A white, rectangular battery pack with a black base and a small connector at the bottom.
<p>Pedals for Single Pedal Brake</p>	 A close-up view of a pedal mechanism with a star-shaped symbol on the side.
<p>Safety Handrail Release (Swing Safety Handrail)</p>	 A view of a swing safety handrail with a release mechanism and an arrow pointing to the release button.
<p>Safety Handrail Release (Slide Safety Handrail)</p>	 A close-up view of a slide safety handrail with a release mechanism and an arrow pointing to the release button.

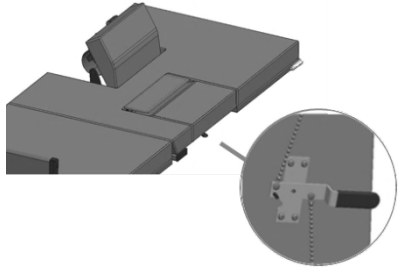
## Controls and Indicators

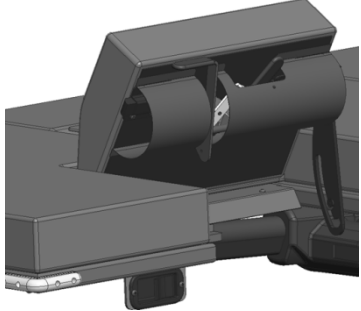
<p>Drop Section Release</p>	 A 3D perspective view of a mechanical component, likely a drop section release. It features a rectangular base with a smaller, angled section on top. A circular inset provides a magnified view of a specific part of the mechanism, showing a small black handle or pin protruding from a series of holes.
<p>Drop Section Remote Release</p>	 A 3D perspective view of a rectangular device, possibly a remote release. It has a silver-colored front edge and a black front panel. A small black rectangular component is attached to the bottom front. A label on the front panel includes the word "WARNING" and a small icon.
<p>Back Rest Release</p>	 A 3D perspective view of a mechanical assembly, likely a back rest release. It shows a large, dark-colored component with a curved, adjustable-looking part on top. The base is rectangular and appears to be mounted on a surface.

# Use Instructions

---

## Powering the Product

The product can be powered by AC power from a wall outlet or by DC power via the optional battery. The product is “on” whenever it is plugged into AC power or when a charged battery is installed. The product should not be positioned in a way that would make it difficult to remove power by unplugging the AC power cord or removing the battery.

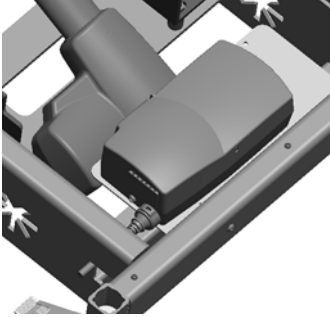
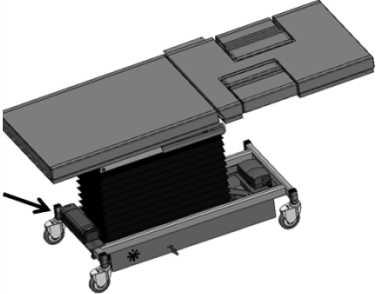
<p>To apply AC power to the product, attach the power cord to the AC input located at the rear of the product.</p>	
<p>To apply DC power to the product, install a battery at the foot end of the product.</p> <p><b>Note:</b> The battery may be charged while it is installed in the product by plugging the product into AC power.</p>	

---

### WARNING

- To reduce the risk of electrical shock, grounding reliability can only be achieved when the equipment is connected to an equivalent receptacle marked “hospital only” or “hospital grade.”
  - If damage has occurred to the power cord, immediately remove the cord from service. Failure to do so could result in serious injury or death.
  - If damage has occurred to the battery, immediately remove the battery from service. Failure to do so could result in serious injury or death.
  - The battery should be periodically inspected for damage. Replace the battery if necessary.
-

# Use Instructions

## Locking the Casters

The product may be equipped with total locking casters or individual locking casters. The total locking casters have 3 functional positions: full swivel, steer, and full lock.

- In the neutral position all four casters may swivel and roll.
- In the steer position the front casters are held in a forward-facing orientation and the rear casters are free to swivel.
- In the lock position all four casters are prevented from both rolling and swiveling.

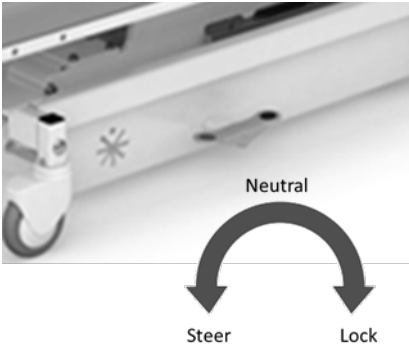
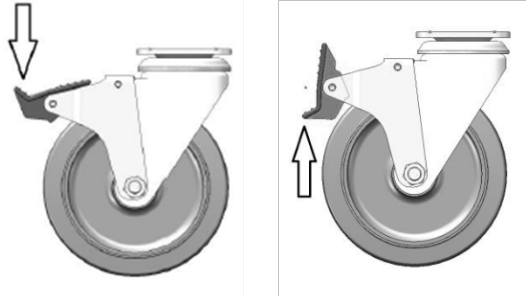
<p><b><u>Single Pedal Braking</u></b></p> <p>Pedals are located on each side of the base and are used to adjust the caster function.</p>	
<p><b><u>Individual Locking Casters</u></b></p> <p>The locking tab is located on each caster. Push down to lock, lift to unlock.</p>	

---

 **WARNING**

- Once the product and patient have been properly positioned for the procedure, ensure the casters are locked and the hand controller is placed in a safe position to prevent unwanted contact and unwanted movement of the product surface during the procedure.
-

# Use Instructions

---

## Hand Control Functions

Hand control functions will vary depending on the model purchased. Your hand control may not include all of the functions listed below.

### Adjusting Surface Height

The minimum surface height is 19" when the surface is level but will stop at heights above this value depending on the angle of Trendelenburg or Reverse Trendelenburg. The limitations are to protect against equipment damage and injury.

Press and hold the applicable hand control function to adjust the seat height.	
--	--

### Adjusting Fowler

The fowler section may be adjusted between 0° and 65°.

Press and hold the applicable hand control function to independently adjust the fowler.	
---	--

### Adjusting Trendelenburg

The Trendelenburg / Reverse Trendelenburg angle is limited at various heights in order to protect against equipment damage and injury. Depending on the product model, the full range of Trendelenburg / Reverse Trendelenburg will be available between 26" – 30" of surface height.

Press and hold the applicable hand control function to independently adjust the Trendelenburg angle.	
--	--

# Use Instructions

---

## Memory Function

Some product configurations have the ability for the user to set memory positions. The control box can store two unique positions for buttons P1 and P2. The memory feature stores the position for height, fowler, and trend.

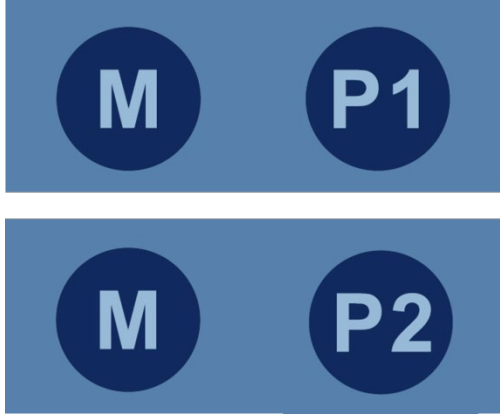
<p>To set a memory position, press and hold the “M” button and then simultaneously press and hold either “P1” or “P2”. The green LED at the top of the hand control will flash 3 times when the memory position has been set. Setting a memory function takes approximately 3-4 seconds.</p> <p>The memory positions can be reset to new positions by following the instructions above.</p>	 <p>The diagram shows two rows of buttons. The top row contains a circular button labeled 'M' and a circular button labeled 'P1'. The bottom row contains a circular button labeled 'M' and a circular button labeled 'P2'. All buttons are white with dark text on a light blue background.</p>
---	--

## Hand Control Lock/Unlock

The hand control function may be locked during the procedure to prevent unwanted movement if the buttons are inadvertently depressed.

<p>Press and hold the lock/unlock button for 3 seconds to lock functions. The green LED at the top of the hand control will light up.</p> <p>Press and hold the lock/unlock button for 3 seconds to unlock functions. The green LED at the top of the hand control will turn off.</p>	 <p>The icon shows a square button with a circular symbol inside. The symbol consists of two padlocks, one open and one closed, with a circular arrow and the number '3' below them, indicating a 3-second hold time.</p>
---	--

# Use Instructions

---

## Under-bed Lights

The product may be equipped with optional under-bed lights.

<p>Press both height up-down buttons to turn on/off the under-bed lights.</p>	
---	--

---

### WARNING

- Verify the area around the product is free of impediments before operating to prevent injury or equipment damage.
  - Keep hands and feet clear from beneath the patient surface when lowering surface height or making positioning adjustments in order to avoid possible injury.
  - Keep hands and feet clear of the scissor lift mechanism when operating or making positioning adjustments in order to avoid possible injury.
  - Keep hands clear of the fowler section hinges during operation to avoid possible injury.
-

## Use Instructions

---

### Using the VasScan Table™ X Footrest

The VasScan Table™ X is equipped with a footrest used during procedures requiring a reverse Trendelenburg position.

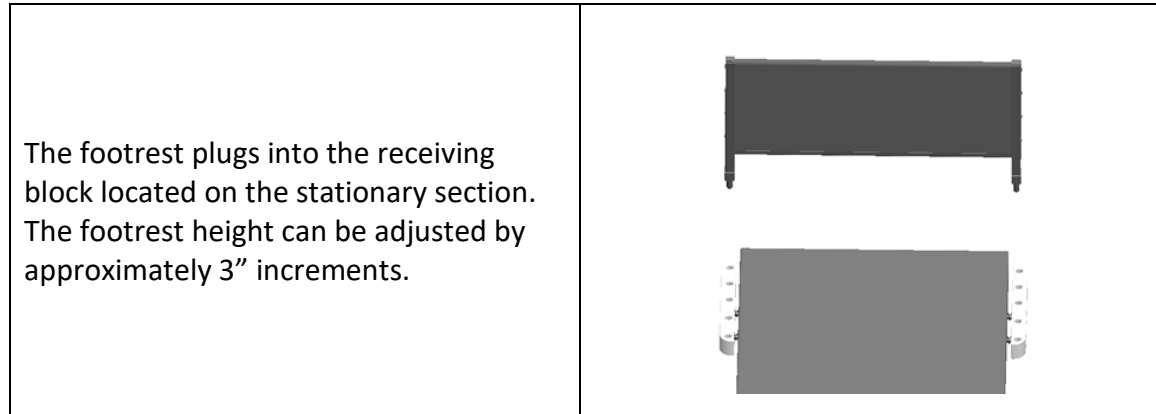

---

 **WARNING**

- The footboard should be used for steep reverse Trendelenburg positions to ensure patient stability.
-

# Use Instructions

## Using the Imaging Drop Section

The imaging drop section is located on the fowler section to allow ergonomic sonographer access to the patient.

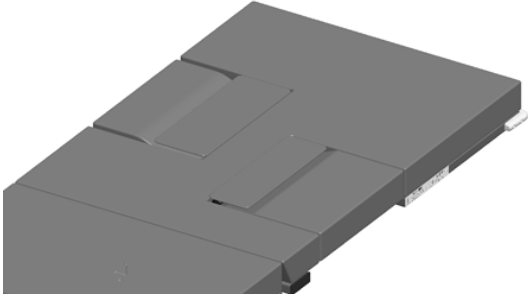
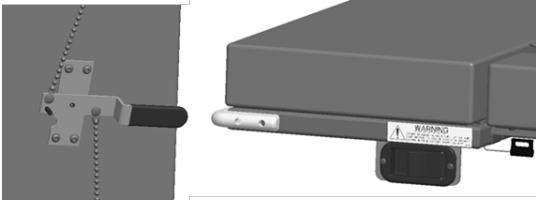
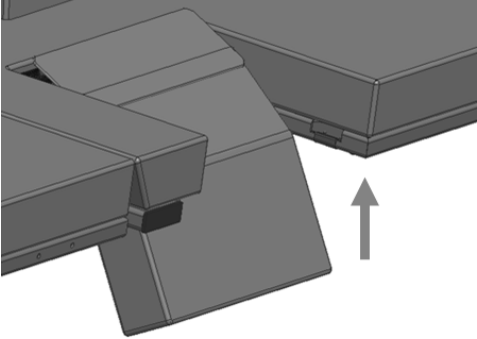
<p>Location of Imaging Drop Section</p>	
<p>To open the drop section, pull the handle to release drop section latches.</p> <p>Or</p> <p>Use the remote release located on the opposite side of the support surface.</p>	
<p>To close the drop section, lift up on the drop section up until latches engage.</p>	

---



 **WARNING**

- Failure to latch Drop Sections may result in patient injury. Verify Drop Sections are locked in position before and after use.
-

# Use Instructions

## Using the Sonographer Drop Sections

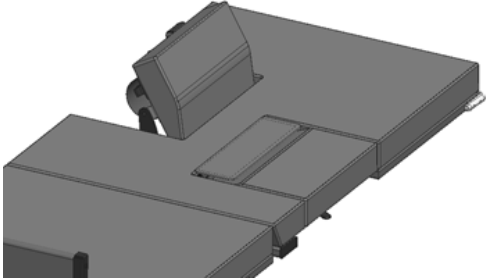
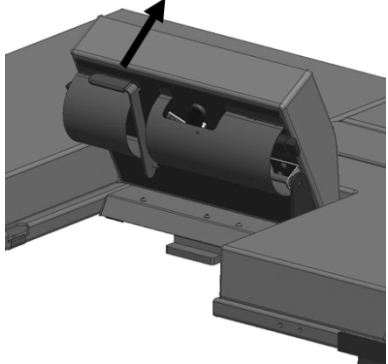
The sonographer drop section allows right-handed scanners to get closer to the patient. It can also be adjusted to act as a patient back rest.

<p>To use the sonographer drop section as a back rest pull up on the drop section until it locks into position. There are two back rest positions to choose from.</p>	
<p>To lower from the back rest position, pull on the handle to release the back rest lock. Hold the handle while lowering the drop section until it returns to its stored position.</p>	
<p>To open the sonographer drop section for better patient access, pull the handle to release the drop section latches. The sonographer may be seated as shown during scanning.</p> <p>To close the drop section, lift up on the drop section up until latches engages.</p>	

### WARNING

- Failure to latch Drop Sections may result in patient injury. Verify Drop Sections are locked in position before and after use.

# Use Instructions

## Using the Carotid Head Rest

The product may be equipped with an optional head support to provide better access during carotid artery scanning. Prior to using the head support the mounting brackets must be installed at the head end of the product.

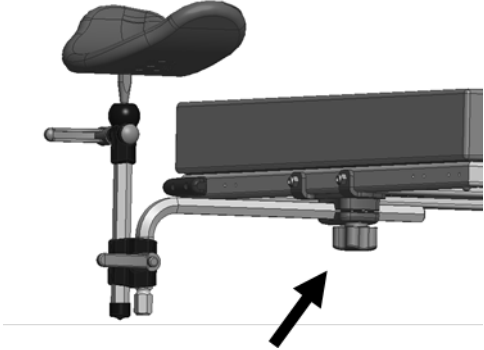
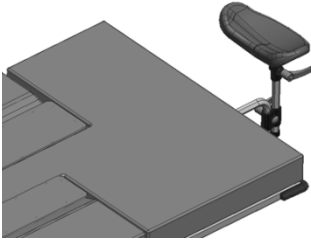
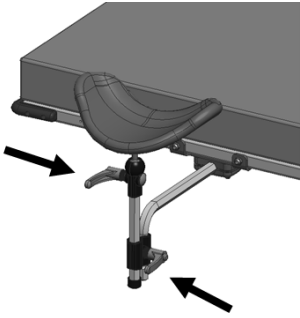
<p>The head rest mount is located underneath the head end of the fowler section.</p>	
<p>Install the head rest and adjust the location. Tighten the knob on the head rest mount to secure.</p>	
<p>Adjust the height and orientation of the head rest using the two control knobs. Tighten to secure.</p>	

---

 **WARNING**

- Verify the head rest is secure prior to using the product.
-

# Use Instructions

---

## Using the Swing Safety Handrails

The product may be equipped with the optional Swing Safety Handrail.

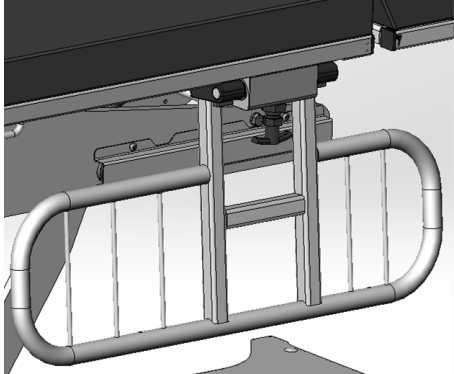
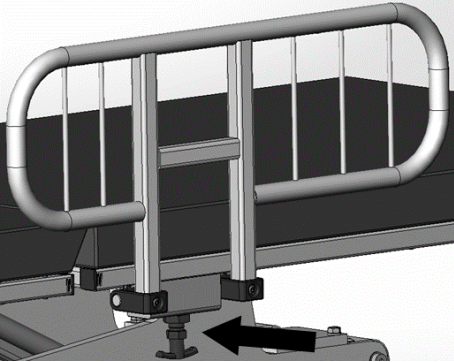
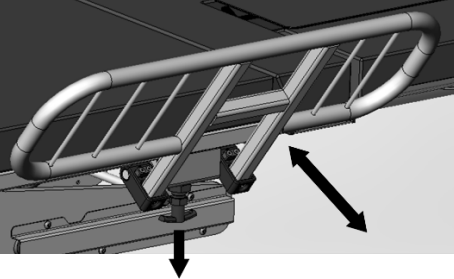
<p>The safety handrails are stored under the support surface when not in use and automatically locked by the spring-loaded locking pin.</p>	
<p>The safety handrails must be locked in the up and down positions by the locking pin.</p>	
<p>The safety handrails may be upright or stored by pulling the release plunger and rotating the safety handrail up or downward.</p>	

---

 **WARNING**

- Verify the safety handrails are secure prior to using the product and after each handrail adjustment.
-

# Use Instructions

---

## Using the Slide Safety Handrails

The product may be equipped with the optional Slide Safety Handrail.

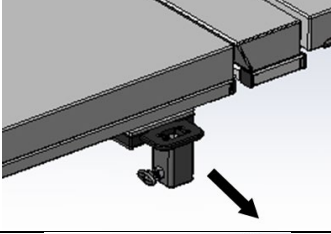
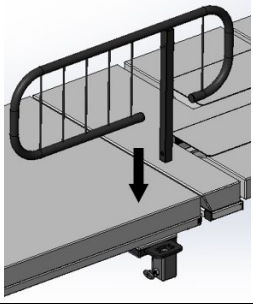
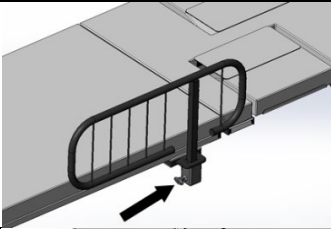
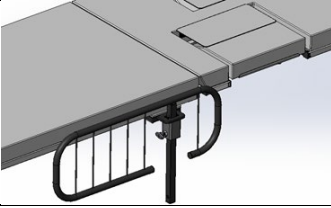
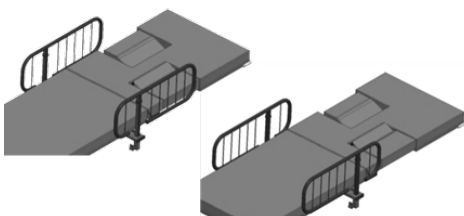
<p>Pull the safety handrail mounting bracket outward.</p>	
<p>Place the safety handrail into the mounting bracket.</p>	
<p>Pull the release plunger and lower the safety handrail so the locking pin engages the hole in the safety handrail.</p>	
<p>The safety handrail may be lowered or removed by pulling on the release plunger.</p>	
<p>The safety handrail may be oriented in multiple directions depending on the access required for the procedure.</p>	

---

 **WARNING**

- Verify the safety handrails are secure prior to using the product and after each handrail adjustment.
-

# Use Instructions

## Using the Sonographer Extension

The product may be equipped with an optional sonographer seat extension. This seat extension allows for a larger seating area for right-handed sonographers.

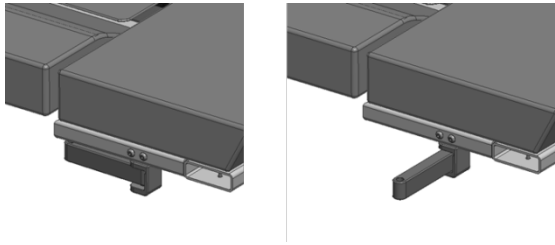
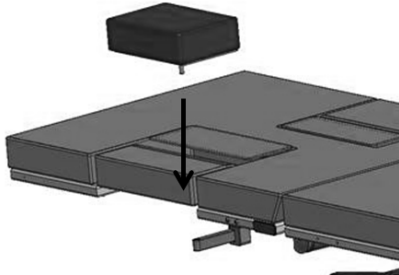
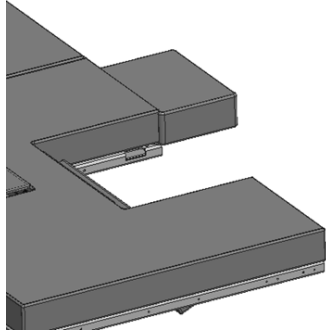
<p>The sonographer seat extension bracket is stored under the support surface when not in use and is pulled out to attach the sonographer's extension.</p>	
<p>The sonographer seat extension is inserted into the bracket and should fit snugly against the upholstery.</p>	
<p>The sonographer drop section should be open to provide the maximum seating area for the sonographer.</p>	

**Note:** When using the sonographer extension, the combined weight of the patient and sonographer shall not exceed the maximum capacity of the product.

**Note:** The product should be positioned at the lowest reasonable height when using the sonographer's extension to ensure maximum stability.

---

 **WARNING**

- Do not exceed the weight capacity of the product.
-

## Use Instructions

### Foley Bag Clip

The product may be equipped with a hook for hanging a Foley bag.

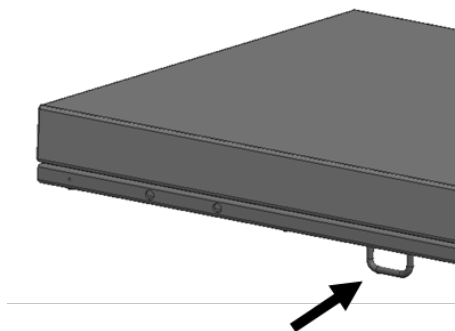

### Storing the Hand Control

The hand control may be hung on the hook located underneath the support surface. The hook may be moved to the end user's preference.

**Note:** If the hand control hook is moved, ensure there is no interference through the product's range of motion.

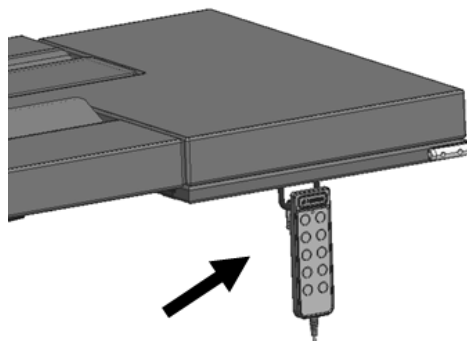

### Under-bed Lights

The product may be equipped with under-bed lights.

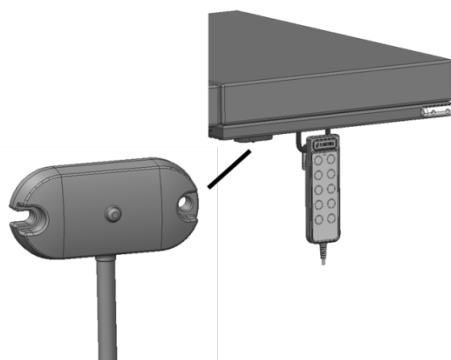

# Use Instructions

## IV Pole and Holder

The product may be equipped with an IV pole. Place the IV pole into the mounting bracket and tighten the knob to secure the IV pole to the product.

The mounting bracket may be located approximately in the locations shown.

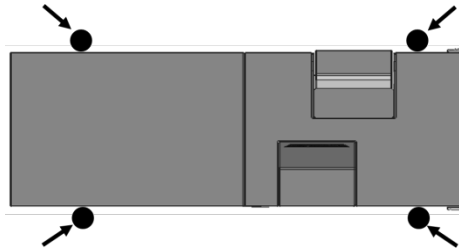

## Optional Battery

The product may be equipped with an optional battery. The battery may be charged by plugging in the product to AC power or by removing the battery and charging it on an external charging station.

To remove the battery, pull the release latch and lift the battery.

**Note:** The lifting capacity of the product is reduced while on battery power. The product will only lift a 500lb patient from the minimum height.

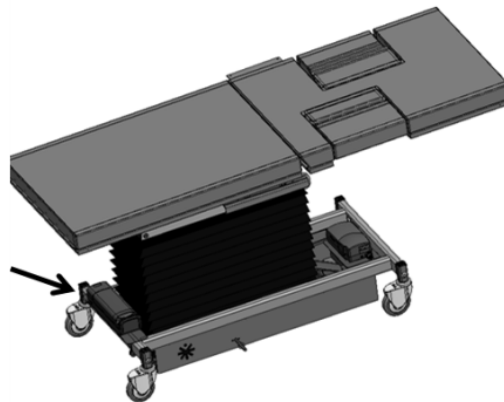

## Use Instructions

---

### Positioning Wedge

The positioning wedge may be used to support the patient at a desired angle.

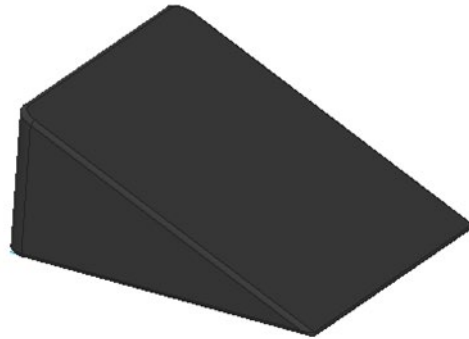

### Pediatric Adaptor

The product may be used with a pediatric/geriatric adaptor. To install use the following steps:

1. Lower the Drop Section
2. Remove the non-pinch closure flap by grasping one side of the flap and gently separating the hook and loop fastener.
3. Position the adaptor locator flanges within the imaging area.
4. Remove the adaptor when not needed.
5. With the drop-section lowered, align the top edge of the non-pinch closure flap, (within the access cavity) with the top edge of the support surface.
6. Press the hook and loop attachment strips together.



## Preventative Maintenance

---

The following Preventative Maintenance should be performed at a minimum annually. If any of these checks fail, repair or replace the part as applicable.

- Visually inspect all mechanical assemblies and moving parts on the product ensuring smooth, steady operation.
- Visually inspect all fasteners (bolts, nuts, screws, etc.) to ensure all are fully installed. Tighten as necessary.
- Visually inspect all electrical cables and wires for signs of abrasion or other damage. If damaged, replace.
- Visually inspect all electrical connections to ensure they are fully and properly connected. Reconnect as necessary.
- Visually inspect the hand control. If damaged, replace.
- Visually inspect the lifting mechanism shroud during raise and lowering. Adjust or replace if necessary.
- Operate all latch mechanisms to ensure proper engagement of latch into receiver. Adjust if necessary.
- Operate all motors to ensure full extension, retraction and correct operation. The motors are permanently lubricated and require no additional lubrication.
- Operate the braking system to ensure proper engagement of the wheel and swivel lock mechanism. Replace as necessary.
- Operate all accessories to ensure proper attachment and operation. Tighten, adjust or replace if necessary.
- Remove the seat cover and visually inspect and operate all mechanical and electrical assemblies as described above.
- Visually inspect the battery for damage. Replace the battery if necessary.
- Unauthorized modification of this product voids any applicable warranty.

---

### WARNING

- No modification of this equipment is allowed.
  - Equipment should only be serviced by authorized personnel.
  - Removal of secured covers may increase the risk of electrical shock. Refer servicing to qualified and authorized personnel.
  - The potential for electrical shock exists with electrical equipment. Failure to follow facility protocols may cause death or serious injury.
-

## Expected Life

---

The expected life of the product is 7 years of normal use. Some components may have a shorter life and require replacement.

Note: See Warranty section for warranty information.

## Discard the Unit

---

Upon reaching the end of its useful life the product may be discarded in accordance with local and federal standards. Recycle when possible.



In accordance with the European Directive 2002/96/EC on Waste Electrical and Electronic Equipment (WEEE), the product must not be disposed as unsorted municipal waste, but should be collected separately. Consult your instructional policies and local regulations regarding disposal. Contact your Medical Positioning, Inc. Service Representative if additional disposal details are required.

# Cleaning

---

## Plastic and Painted Surfaces

The painted metal and plastic surfaces can be cleaned with normal cleaners and disinfectant.

STEP	ACTION
1	Clean and/or disinfect with liquid cleaner of choice being careful to follow label instructions provided with cleaner. (Always test a small area first to determine suitability of solution)
2	Wipe the surface clean with a damp cloth after applying cleaners and disinfectant to remove excess residue buildup.

## Vinyl

The vinyl upholstered surfaces can be cleaned in one of the following ways:

The preferred method of everyday cleaning is using a soft cloth or sponge with mild soap and water or disinfectant. Spills and accidents require immediate attention for best results. When caught quickly, most stains such as grease, blood and felt tip pens can be wiped right off. Mild soap and water is the preferred method; however, typical hospital-grade antiseptic wipes work as well. For more stubborn stains, a variety of concentrated and solvent type cleansers may be used without damaging the surface as long as they are thoroughly rinsed off with water.

Generally speaking, always start with the mildest cleaning agents first. Never use harsh powdered abrasive cleansers or steel wool. Products containing bleach, ammonia or alcohol should be wiped from the surface with a wet cloth after use. Residue from these products will damage vinyl surfaces.

STEP	ACTION
1	Clean and/or disinfect with liquid cleaner while being careful to follow label instructions provided with cleaner. (Always test a small area first to determine suitability of solution)
2	Wipe the surface clean with a damp cloth after applying cleaners and disinfectant to remove excess residue buildup.

# Cleaning

RECOMMENDED MAXIMUM CLEANER TO WATER SOLUTIONS	
	Mildest 1:1 mix of mild soap and water. Wipe surface with damp cloth with water only after cleaning.
	Straight application of common disinfectants. Wipe surface with damp cloth with water only after cleaning.
	1:1 mix of ammonia and water. Use a soft cotton cloth saturated with the cleaning material. Wipe surface with damp cloth with water only after cleaning.
	1:4 mix of bleach and water. Use a soft cotton cloth saturated with the cleaning material. Wipe surface with damp cloth with water only after cleaning.
	1:1 mix of isopropyl alcohol and water. Use a soft cotton cloth saturated with the cleaning material. Wipe surface with damp cloth with water only after cleaning.
	Straight application of isopropyl alcohol. Use a soft cotton cloth saturated with the cleaning material. Wipe surface with damp cloth with water only after cleaning.
	Strongest 1:1 mix of acetone and water. Use a soft cotton cloth saturated with the cleaning material. Wipe surface with damp cloth with water only after cleaning.

This information is not a guarantee and does not relieve the user from the responsibility of proper and safe use of the product and all cleaning agents.

## WARNING

- It is recommended that the product be cleaned between patients; please follow your facility's documented policy.

## CAUTION

- Always read manufacturer's instructions and warnings before using any cleaning product or disinfectant.
- Substances such as imaging gels and alcohol will not damage the vinyl surface when immediately removed. Studies have shown that exposure for longer than a few minutes can damage the topcoat and will eventually discolor vinyl.
- Do not use abrasives to clean painted surfaces.

## Service Calls

---

A “**Troubleshooting Guide**” is included to instruct you in the event of a malfunction. If you are experiencing any of the following symptoms, this guide may help you quickly solve the problem. If, after consulting this guide, you are still unable to operate your product please contact Medical Positioning at 1-800-593-3246. Please have the following information ready when you call:

1. Model Number or Name of Product
2. Serial Number
3. Date Received
4. Condition When Received
5. Symptom (or problem) Encountered & Result of Troubleshooting Procedure

### Complaint Reporting Procedure

In the event of a product malfunction or patient injury, please immediately report the incident to:

1. \_\_\_\_\_  
(The distributor from whom the product was purchased)
2. Medical Positioning, Inc.  
9732 Pflumm Road  
Lenexa, KS 66215  
[www.MedicalPositioning.com](http://www.MedicalPositioning.com)  
816-474-1555  
800-593-3246 (ECHO)

# Troubleshooting Guide

SYMPTOM	PROBABLE CAUSE	SUGGESTION
No Actuator Function Actuator(s) Not Running.	<ul style="list-style-type: none"> <li>Power cord not plugged all the way into wall receptacle.</li> </ul>	<ul style="list-style-type: none"> <li>Push power cord securely into receptacle.</li> </ul>
	<ul style="list-style-type: none"> <li>Power outlet receptacle not supplying 120 VAC power.</li> </ul>	<ul style="list-style-type: none"> <li>Check power availability or plug unit into another receptacle.</li> </ul>
	<ul style="list-style-type: none"> <li>The power cord may be separated from the control box.</li> </ul>	<ul style="list-style-type: none"> <li>Securely press power cord into control box.</li> </ul>
	<ul style="list-style-type: none"> <li>Battery may be drained.</li> </ul>	<ul style="list-style-type: none"> <li>Replace or charge battery.</li> </ul>
	<ul style="list-style-type: none"> <li>Actuator cord may be unplugged.</li> </ul>	<ul style="list-style-type: none"> <li>Push actuator cords securely into actuator receptacle.</li> </ul>
	<ul style="list-style-type: none"> <li>Product was overloaded and tripped internal fuse in control box.</li> </ul>	<ul style="list-style-type: none"> <li>Replace control box.</li> </ul>
	<ul style="list-style-type: none"> <li>Product motion is limited at certain heights and angles.</li> </ul>	<ul style="list-style-type: none"> <li>Return the surface to a level position to restore full range of motion</li> </ul>
	<ul style="list-style-type: none"> <li>The product will not move when hand control buttons are pressed.</li> </ul>	<ul style="list-style-type: none"> <li>The hand control buttons may be locked. If the green LED on the hand control is lit, then press the unlock button for 3 seconds to unlock the hand control functions.</li> </ul>
Squeaking noises during operation.	<ul style="list-style-type: none"> <li>Actuator pins are not sufficiently lubricated</li> </ul>	<ul style="list-style-type: none"> <li>Apply WD40 or similar lubricant to actuator pins.</li> </ul>

 **WARNING**

- Do not modify this equipment without authorization of the manufacturer.
- Removal of secured covers may increase the risk of electrical shock. Refer servicing to qualified personnel.
- The battery should be periodically inspected for damage. Replace the battery if necessary.

# Specifications

---

## Product Models & Attributes

Depending on the country of sale and the options chosen the model number may be slightly different than what is shown below. For example, the model number may be followed by a country code such as 201UK or 201EU. Additionally the model number may be followed by an option code such as 201UK-A or 201-A.

**Note:** The products covered by this manual are designed to support a 1000lb static load for emergency situations. The specified maximum patient weight should be followed for normal usage.

EchoBed® X					
ATTRIBUTE	201	222	223	233	022
Base Width	26"	26"	26"	26"	26"
Base Length	48.5"	48.5"	48.5"	48.5"	48.5"
Surface Width	30"	30"	30"	30"	30"
Surface Length	80.5"	80.5"	80.5"	80.5"	80.5"
Surface Height Range *To top of cushion	19" – 38"	19" – 38"	19" – 38"	19" – 38"	19" – 38"
Trendelenburg/ Reverse Trendelenburg	-	-	15° / 15°	15° / 15°	-
Fowler Range	-	0° - 65°	-	0° - 65°	0° - 65°
# of Drop Sections	2	2	2	2	0
Maximum Patient Weight	600lb	600lb	600lb	600lb	600lb
Maximum Safe Working Load	625lb	625lb	625lb	625lb	625lb
Approximate Product Weight	430lb	440lb	440lb	440lb	430lb

# Specifications

---

<b>VasScan Table™ X</b>		
<b>ATTRIBUTE</b>	<b>084</b>	<b>284</b>
Base Width	26"	26"
Base Length	48.5"	48.5"
Surface Width	28"	28"
Surface Length	80.5"	80.5"
Surface Height Range *To top of cushion	19" – 38"	19" – 38"
Trendelenburg/ Reverse Trendelenburg	15° / 30°	15° / 30°
Fowler Range	0° - 65°	0° - 65°
# of Drop Sections	0	2
Maximum Patient Weight	600lb	600lb
Maximum Safe Working Load	625lb	625lb
Approximate Product Weight	420lb	420lb

# Specifications

---

## Environmental Conditions

ATTRIBUTE	Range for Use	Range for Storage and Transport
Ambient Temperature	+0° to 40° C	-10° to +50° C
Relative Humidity	20% to 90% @ 30°C – not condensing	20% to 90% @ 30°C – not condensing
Atmospheric Pressure	860 to 1060 hPa	860 to 1060 hPa

## Upholstery

ATTRIBUTE	SPECIFICATION
Foam	California Technical Bulletin 117

## Power Requirements

ATTRIBUTE	SPECIFICATION
Electrical, Product	100–240 VAC, 50/60 Hz, max 5 A
Electrical, Battery Charger	100–240 VAC, 50/60 Hz
Battery Option	24 VDC, 2.9 Ah
Duty Cycle	10%, 2 min. on / 18 min. off

- All electrical circuitry is isolated from chassis.
- Grounding reliability can only be achieved when the equipment is connected to an equivalent receptacle marked “Hospital Only” or “Hospital Grade.”
- The power cord is to be used for mains disconnection.
- Attached power supply cord set is not allowed to be diverted to other equipment.

# Specifications

---

## Classifications and Standards

ATTRIBUTE	SPECIFICATION
Standards	<ul style="list-style-type: none"><li>• IEC 60601-1:2005 + A1:2012</li><li>• ANSI/AAMI ES60601-1:2005/(R)2012 and A1:2012, C1:2009/(R)2012 and A2:2010/(R)2012</li><li>• CAN/CSA-C22.2 NO. 60601-1:14</li><li>• EN 60601-1:2006 +A11:2011 +A1:2013 +AC:2014</li><li>• IEC 60601-1-2:2007</li><li>• EN/ISO 14971:2012</li></ul>
Protection against Electrical Shock	<ul style="list-style-type: none"><li>• Class I equipment</li><li>• Type B applied part</li></ul>
Degree of protection against Dust and Fluid intrusion	<ul style="list-style-type: none"><li>• IPX0</li></ul>

# Specifications

---

## Applied Parts (in accordance with IEC 60601-1)

- All padded surfaces
- Arm rests
- Footrest
- Straps

## Electromagnetic Emissions Guidance

The product use components that meet the requirements for IEC 60601-1-2. Other products that are used in the vicinity of this product should also comply with this standard. If they do not comply, electromagnetic interference between the products could cause the products to operate incorrectly. If problems do occur, contact the product manufacturer(s).

Make sure the product operates correctly when used near other electronic devices. Portable and mobile radio frequency (RF) communications equipment can affect electrical equipment.

---

 **WARNING**

- If the product is used adjacent to other electrical equipment, observe this product and the other electrical equipment to make sure they operate as intended.
-

# Specifications

---

## Electromagnetic Compatibility

Medical electrical equipment needs special precautions regarding electromagnetic compatibility (EMC) and needs to be installed and put into service according to the EMC information provided in this user manual.

Portable and mobile radio frequency (RF) communications equipment can affect medical electrical equipment.

<b>Guidance and Manufacturer's Declaration - Electromagnetic Emissions</b>		
The product is intended for use in the electromagnetic environments specified below. The customer or the user of the product should assure it is used in such an environment.		
<b>Emissions Test</b>	<b>Compliance</b>	<b>Guidance</b>
RF Emissions CISPR 11	Group 1 Group 2	The product uses RF energy only for its internal function. Therefore, its RF emissions are very low and are not likely to cause any interference in nearby electronic equipment. <1>  The product must emit electromagnetic energy in order to perform its intended function. Nearby electronic equipment may be affected. <2>
RF Emissions CISPR 11	Class A	The product is suitable for use in all establishments other than domestic and those directly connected to the public low-voltage power supply network that supplies buildings used for domestic purposes.
Harmonic Emissions IEC 61000-3-2	N/A	
Voltage Fluctuations/ Flicker Emissions IEC 61000-3-3	N/A	

# Specifications

<b>Guidance and Manufacturer's Declaration - Electromagnetic Immunity</b>			
The product is intended for use in the electromagnetic environments specified below. The customer or the user of the product should assure it is used in such an environment.			
<b>Immunity Test</b>	<b>IEC 60601 Test Level</b>	<b>Compliance Level</b>	<b>Guidance</b>
Electrostatic Discharge IEC 61000-4-2	± 6 kV Contact ± 8 kV Air	± 6 kV Contact ± 8 kV Air	Floors should be wood, concrete, or ceramic tile. If floors are covered with synthetic material, the relative humidity should be at least 30%.
Electrical Fast Transient/ Burst IEC 61000-4-4	± 2 kV on power Supply Lines ± 1 kV on Input/Output Lines	± 2 kV on Power Supply Lines ± 1 kV on Input/Output Lines	Mains power quality should be that of a typical commercial or hospital environment
Surge IEC 61000-4-5	± 1 kV Differential Mode ± 2 kV Common Mode	± 1 kV Differential Mode ± 2 kV Common Mode	Mains power quality should be that of a typical commercial or hospital environment
Voltage Dips, Short Interrupts, & Variations on Power Supply Lines IEC 61000-4-11	< 5% $U_T$ (95% dip in $U_T$ for 0.5 cycles)  < 40% $U_T$ (60% dip in $U_T$ for 5 cycles)  < 70% $U_T$ (30% dip in $U_T$ for 25 cycles)	< 5% $U_T$ (95% dip in $U_T$ for 0.5 cycles)  < 40% $U_T$ (60% dip in $U_T$ for 5 cycles)  < 70% $U_T$ (30% dip in $U_T$ for 25 cycles)	Mains power quality should be that of a typical commercial or hospital environment. If the user of the product requires continued operation during mains interruptions, it is recommended that the product be powered from an uninterruptible power supply or a battery.
Power Frequency Magnetic Fields IEC 61000-4-8	3 A/m	3 A/m	Power frequency magnetic fields should be at levels characteristic of a typical location in a typical commercial or hospital environment.
NOTE $U_T$ is the a.c. mains voltage prior to application of the test level			

# Specifications

Guidance and Manufacturer's Declaration - Electromagnetic Immunity			
The product is intended for use in the electromagnetic environments specified below. The customer or the user of the product should assure it is used in such an environment.			
Immunity Test	IEC 60601 Test Level	Compliance Level	Guidance
Conducted RF IEC 61000-4-6	3 Vrms 150 kHz to 80 Mhz	3 Vrms	<p>Portable and mobile RF communications equipment should be used no closer to any part of the product, including cables, than the recommended separation distance calculated from the equation applicable to the frequency of the transmitter.</p> <p><b>Recommended separation distance</b></p> $d = 1,2\sqrt{P}$ $d = 1,2\sqrt{P} \quad 80 \text{ MHz to } 800 \text{ MHz}$ $d = 2,3\sqrt{P} \quad 800 \text{ MHz to } 2.5 \text{ GHz}$ <p>Where <math>P</math> is the maximum output power rating of the transmitter in watts (W) according to the transmitter manufacturer and <math>d</math> is the recommended separation distance in meters (m).</p> <p>Filed strengths from fixed RF transmitters, as determined by an electromagnetic site survey,<sup>a</sup> should be less than the compliance level in each frequency range.<sup>b</sup></p> <p>Interference may occur in the vicinity of equipment marked with the following symbol:</p> 
Radiated RF IEC 61000-4-3	3 Vrms 80 MHz to 2.5 GHz	3 V/m	
<p>NOTE 1 At 80 MHz and 800 MHz, the higher frequency range applies.</p> <p>NOTE 2 These guidelines may not apply in all situations. Electromagnetic propagation is affected by absorption and reflection from structures, objects and people.</p> <p><sup>a</sup> Field strengths from fixed transmitters, such as base stations for radio (cellular/cordless) telephones and land mobile radios, amateur radio, AM and FM radio broadcast and TV broadcast cannot be predicted theoretically with accuracy. To assess the electromagnetic environment due to fixed RF transmitters, an electromagnetic site survey should be considered. If the measured field strength in the location in which the product is used exceeds the applicable RF compliance level above, the product should be observed to verify normal operation. If abnormal performance is observed, additional measures may be necessary, such as reorienting or relocating the product.</p> <p><sup>b</sup> Over the frequency range 150 kHz to 80 MHz, field strengths should be less than [V1] V/m.</p>			

# Specifications

Recommended separation distances between portable and mobile RF communications equipment and the MPI Echo/Vascular Products			
The product is intended for use in an electromagnetic environment in which radiated RF disturbances are controlled. The customer or the user of the product can help prevent electromagnetic interference by maintaining a minimum distance between portable and mobile RF communications equipment (transmitters) and the product as recommended below, according to the maximum output power of the communications equipment.			
Rated maximum output power of transmitter	Separation distance according to frequency of transmitter (m)		
	150 kHz to 80 MHz	80 MHz to 800 MHz	800 MHz to 2.5 GHz
	$d = 1,2\sqrt{P}$	$d = 1,2\sqrt{P}$	$d = 2,3\sqrt{P}$
0.01	0,12	0,12	0,23
0.1	0,38	0,38	0,73
1	1,2	1,2	2,3
10	3,8	3,8	7,3
100	12	12	23
For transmitters rated at a maximum output power not listed above, the recommended separation distance $d$ in meters (m) can be estimated using the equation applicable to the frequency of the transmitter, where $P$ is the maximum output power rating of the transmitter in watts (W) according to the transmitter manufacturer.			
NOTE 1 At 80 MHz and 800 MHz, the separation distance for the higher frequency range applies.			
NOTE 2 These guidelines may not apply in all situations. Electromagnetic propagation is affected by absorption and reflection from structures, objects and people.			

# Specifications

## Standard and Optional Configurations

ATTRIBUTE	EchoBed® X		VasScan Table™ X	
	STANDARD	OPTIONAL	STANDARD	OPTIONAL
Hand control	X	-	X	-
Safety Handrails	X	-	-	X
Single Pedal Brake/Mobility	X	-	-	X
Paper Roll Holder	-	X	-	X
Positioning Wedge	-	X	-	X
Sonographer Extension	-	X	-	X
1 Function Foot Control	-	X	-	X
3 Function Foot Control	-	X	-	X
IV Pole & Holder	-	X	-	X
Battery Functionality	-	X	-	X
2nd Battery & Charger Kit	-	X	-	X
Under-bed Lights	-	X	-	X
Footboard	-	-	X	-

# Specifications

---

## Replacement Parts and Upgrade Kits

The following items are replacements parts or upgrade kits for the EchoBed® X and VasScan Table™ X. Some of the items below may not be suitable for all models of product.

Part Description	Part #
Hand Control <sup>1</sup>	See Note Below
1 Function Foot Control	15543
3 Function Foot Control	15544
Multi-Function Control Kit	15505
Paper Roll Holder Kit	10098
Swing Safety Handrail Kit (EchoBed X)	16152
Swing Safety Handrail Kit (VasScan Table X)	16151
Slide Safety Handrail Kit	16156
IV Pole Kit	10855
Battery Functionality	15509
Replacement Battery	15395
Wall Charger Kit	15508
VasScan Footboard	14460
Carotid Headrest Kit	15507
Underbed Hook Kit	15510
Underbed Light Kit <sup>2</sup>	15511
Sonographer Extension Kit	15512
Sonographer Seat Replacement	15513
Pediatric/Geriatric Adapter	10097
Positioning Wedge	11943
Armboard Kit- VasScan X	11020
Armboard Kit- EchoBed X	15552

1. The hand control part number is specific to the product model. Please provide the product model when ordering a new hand control.
2. The Multi-Function Control Kit is required with the Under-bed Light Kit.

# Warranty

---

## Warranty

VasScan Table™ X

**2**

### YEAR WARRANTY

Medical Positioning, Inc. ("MPI") warrants and represents that this product will be free from material and workmanship defects during the period indicated above (the "Warranty Period"), commencing with tender of delivery as defined in Uniform Commercial Code § 2-503, irrespective of any inspection period and provided that the product is maintained and operated in accordance with MPI's specifications.

If the product fails due to a manufacturing defect, MPI will, at its sole expense and discretion, repair the product, authorize repairs to the product, or replace the product. MPI will ship any replacement products or parts using standard shipping rates; if the customer requires expedited shipping of replacement products or parts, the customer is responsible for paying shipping costs above standard rates.

Preventative maintenance and repairs due to damage by use, accident, improper care, negligence, or other non-defect related failures are not covered by this warranty. This warranty is void as to products that have been modified without the advance written permission of MPI.

OTHER THAN AS SET FORTH HEREIN, MPI MAKES NO WARRANTY WHATSOEVER, EITHER EXPRESSED OR IMPLIED, WITH RESPECT TO THIS PRODUCT. MPI SPECIFICALLY DISCLAIMS THE (a) IMPLIED WARRANTY OF MERCHANTABILITY; (b) WARRANTY OF FITNESS FOR A PARTICULAR PURPOSE; AND (c) WARRANTY AGAINST INFRINGEMENT OF ANY PATENT, COPYRIGHT, TRADEMARK, TRADE SECRET OR OTHER PROPRIETARY RIGHTS OF A THIRD PARTY; WHETHER ARISING BY LAW, COURSE OF DEALING, COURSE OF PERFORMANCE, USAGE OF TRADE OR OTHERWISE.

This warranty is nontransferable. The remedies provided under this warranty are the customer's sole and exclusive remedies. In no event will MPI be liable for any direct, indirect, special, incidental, consequential damages or lost profits or income whether based on contract, tort, or any other legal theory.

**Medical Positioning, Inc.**

9732 Pflumm Road  
Lenexa, Kansas 66215  
(816) 474-1555  
(800) 593-3246  
Fax (816) 474-7755

WAR069-B

# Warranty

---

## Warranty

### EchoBed X 5 YEAR WARRANTY

Medical Positioning, Inc. ("MPI") warrants and represents that this product will be free from material and workmanship defects during the period indicated above (the "Warranty Period"), commencing with tender of delivery as defined in Uniform Commercial Code § 2-503, irrespective of any inspection period and provided that the product is maintained and operated in accordance with MPI's specifications.

If the product fails due to a manufacturing defect, MPI will, at its sole expense and discretion, repair the product, authorize repairs to the product, or replace the product. MPI will ship any replacement products or parts using standard shipping rates; if the customer requires expedited shipping of replacement products or parts, the customer is responsible for paying shipping costs above standard rates.

Preventative maintenance and repairs due to damage by use, accident, improper care, negligence, or other non-defect related failures are not covered by this warranty. This warranty is void as to products that have been modified without the advance written permission of MPI.

OTHER THAN AS SET FORTH HEREIN, MPI MAKES NO WARRANTY WHATSOEVER, EITHER EXPRESSED OR IMPLIED, WITH RESPECT TO THIS PRODUCT. MPI SPECIFICALLY DISCLAIMS THE (a) IMPLIED WARRANTY OF MERCHANTABILITY; (b) WARRANTY OF FITNESS FOR A PARTICULAR PURPOSE; AND (c) WARRANTY AGAINST INFRINGEMENT OF ANY PATENT, COPYRIGHT, TRADEMARK, TRADE SECRET OR OTHER PROPRIETARY RIGHTS OF A THIRD PARTY; WHETHER ARISING BY LAW, COURSE OF DEALING, COURSE OF PERFORMANCE, USAGE OF TRADE OR OTHERWISE.

This warranty is nontransferable. The remedies provided under this warranty are the customer's sole and exclusive remedies. In no event will MPI be liable for any direct, indirect, special, incidental, consequential damages or lost profits or income whether based on contract, tort, or any other legal theory.

**Medical Positioning, Inc.**

9732 Pflumm Road  
Lenexa, Kansas 66215  
(816) 474-1555  
(800) 593-3246  
Fax (816) 474-7755

WAR069-B

## **Return Policy**

---

MPI accepts returns of unused products within 30 days from the date of delivery, irrespective of any inspection period. Returns are subject to a 30% restocking fee, any applicable duties or taxes and quality inspection. No product may be returned without prior written authorization from MPI. The customer is responsible for all shipping charges and any applicable duties or taxes incurred in connection with a return.

WAR093-A